

IN SWING DOOR WITH 5 INCH IN SILL

FOR ILLUSTRATION PURPOSES ONLY - NOT TO SCALE

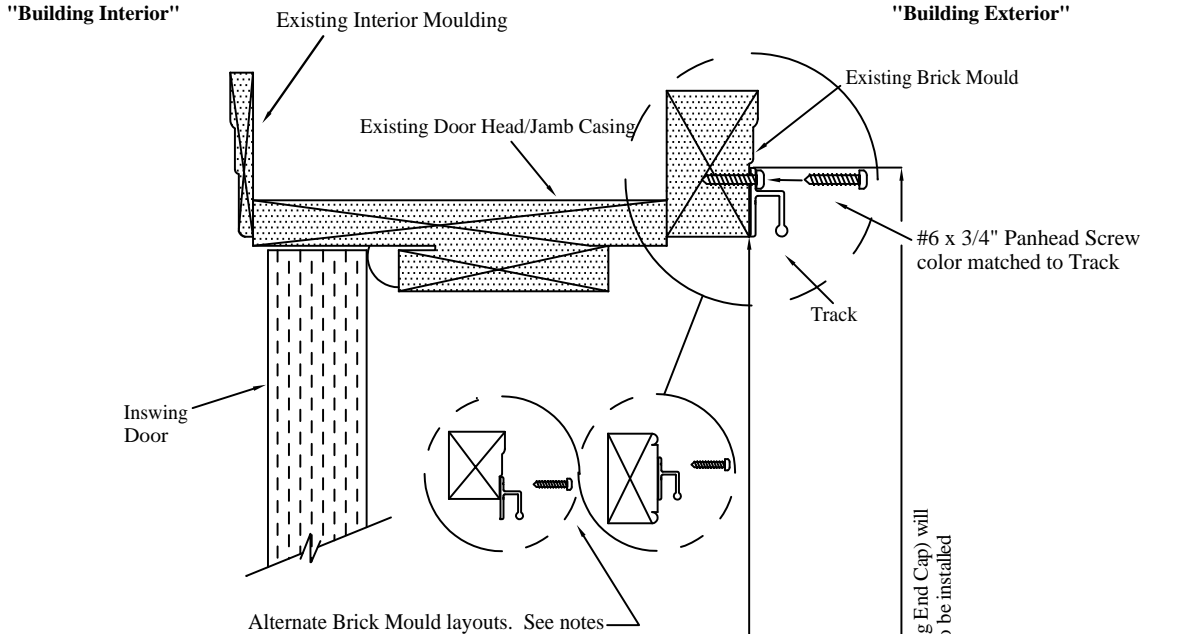

NOTES:

Predrill the sill adapter (5" In Sill) with a 5/32" diameter hole, then bore out that predrilled hole with a #6 Countersink Bit. Sill adapters will require a minimum of three fasteners/holes for proper installation - two at three inches from each end and one centered in the middle.

The existing door casings (sill, head & jamb) and brick mould shown are only one example of what is available. The illustrations are only intended to show the use of a vertically flat section for mounting Track. A higher mounting location is recommended when applicable.

Hanging the Track below the bottom of the casing/moulding without a square sill adapter is acceptable, as long as at least 1/2" of flat surface is available for mounting the Track.

All fasteners are corrosion resistant. See "Fastener Reference Guide" for details.

